

► **Code Number**

3772680

► **Description**

Exposed, Sensor Activated Sloan® Model Water Closet Flushometer for top spud bowls.

► **Flush volume**

1.0 gpf/3.8 Lpf

► **Specifications**

Quiet, Exposed, Diaphragm Type, Chrome Plated Closet Flushometer with the following features:

- 1" I.P.S. Screwdriver Bak-Chek® Angle Stop with Vandal Resistant Stop Cap
- Sweat Solder Adapter with Cover Tube and Cast Wall Flange
- Low Consumption flush accuracy
- Handle Packing, Main Seat, Stop Seat and Vacuum Breaker Molded from PERMEX® Rubber Compound for Chloramine resistance
- User friendly three (3) second Flush Delay
- OPTIMA® EL-1500 Self-Adaptive Infrared Sensor with Indicator Light
- "Walk By" Delay of Eight (8) Seconds Prevents Unintentional Flushes
- Non-Hold-Open Integral Solenoid Operator, Fixed Metering Bypass and No External Volume Adjustment to Ensure Water Conservation
- Vacuum Breaker Flush Connection with One-Piece Bottom Hex Coupling Nut, Spud Coupling and Flange for 1½" Top Spud

Valve Body, Cover, Tailpiece and Control Stop shall be in conformance with ASTM Alloy Classification for Semi-Red Brass. Valve shall be in compliance with the applicable sections of ASSE 1037 and ANSI/ASME 112.19.2.

► **Variations**

No Sentinel Flush

► **Accessories (Sold Separately)**

- EL-154 120 VAC/24 VAC, 50/60 Hz (50 VA) - Box Mount
- Transformer (240 VAC/24 VAC, 50 VA) EL-342

See Accessories Section and OPTIMA® Accessories Section of the Sloan catalog for details on these and other OPTIMA® Flushometer variations.

► **Fixtures**

Consult factory for matching Sloan brand fixture options.

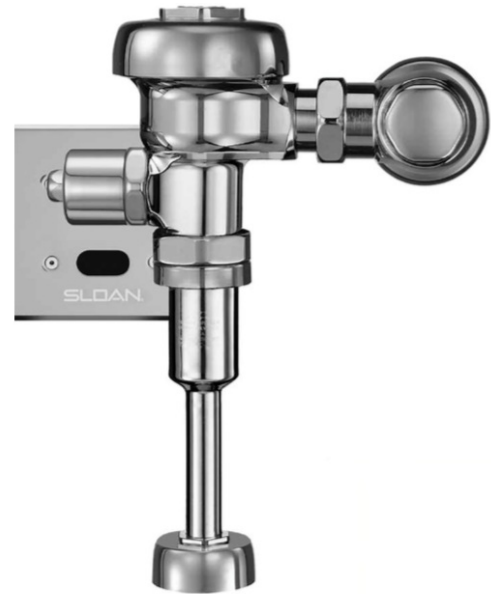

► **Automatic Operation**

Sloan OPTIMA® equipped Flushometers provide the ultimate in sanitary protection and automatic operation. There are no handles to trip or buttons to push. The Flushometer operates by means of an infrared sensor that adapts to its surrounding. Once the user enters the sensor's effective range and then steps away, the Flushometer Solenoid initiates the flushing cycle to flush the fixture.

► **Hygienic**

User makes no physical contact with the Flushometer surface except to initiate the Override Button when required. Helps control the spread of infectious diseases.

► **Economical**

Automatic operation provides water usage savings over other flushing devices. Reduces maintenance and operation costs.

► **Practical**

Solid state electronic circuitry assures years of dependable, troublefree operation. The operational components of the Flushometer are identical to a handle activated Royal® Flushometer, proven by over 100 years of experience.

► **Compliance & Certifications**



This space for Architect/Engineer Approval

► **ELECTRICAL BOX INSTALLATION**

SLOAN 10500 SEYMOUR AVE. • FRANKLIN PARK, • IL. 60131

Ph: 1-800-9-VALVE-9 or 1-847-671-4300 • Fax: 1-800-447-8329 or 1-847-671-4380 • <http://www.sloan.com>

### ► ELECTRICAL SPECIFICATIONS

#### Control Circuit

- Solid State
- 3 Second Flush Delay
- 24 VAC Input
- 24 VAC Output

16 Second Arming Delay

#### Sensor Range

- Nominal 22" - 42" (559 mm - 1067 mm) Self-adaptive Window: ± 10" (254 mm)

#### Solenoid Operator

- 24 VAC, 50/60 Hz

#### Transformers

- Sloan Part #EL-154 120 VAC, 50/60 Hz Primary 24 VAC, 50/60 Hz Secondary Class II, UL Listed, 50 VA.
- Sloan Part #EL-342 240 VAC, 50/60 Hz Primary 24 VAC, 50/60 Hz Secondary Class II, UL Listed, 50 VA.

### ► OPERATION

1. A continuous, invisible light beam is emitted from the OPTIMA Sensor.

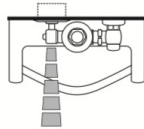

2. As the user enters the beam's effective range (15" to 30") the beam is reflected into the OPTIMA Scanner Window and transformed into a low voltage electrical circuit. Once activated, the Output Circuit continues in a "hold" mode for as long as the user remains within the effective range of the Sensor.

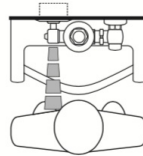

3. When the user steps away from the OPTIMA Sensor, the circuit immediately initiates an electrical "one-time" signal that operates the Solenoid. This initiates the flushing cycle to flush the fixture. The Circuit then automatically resets and is ready for the next user.

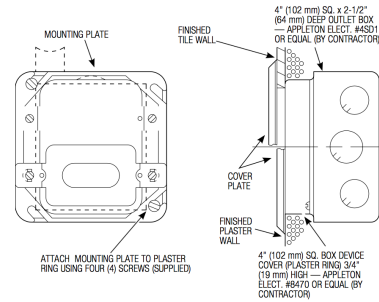
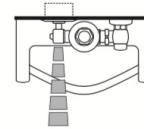

### ► WIRING DIAGRAM

One Transformer serves up to ten (10) OPTIMA Closet/ Urinal Flushometers. Specify number of transformers required accordingly.

